

Subjective Measurement of Noise and Vibration Using Objective Techniques

Klaus Genuit, HEAD acoustics GmbH, Herzogenrath, Germany
Mahlon Burkhard, Sonic Perceptions, Inc., Norwalk, CT

Because sound events in cars arise in a complex way, direct conclusions about causes and transmission paths of sound components judged to be annoying can be drawn only in a limited way. A procedure for measurement and analysis has been developed to complement binaural measurement technology by including multichannel measurements of acceleration sensor signals, sound radiation and transmission. For an automobile, this involves correlating signals influencing sound quality with signals analyzed by means of human hearing and with signals from acceleration sensors fixed in front of and behind engine mounts. An exact relationship between physical causes and subjectively perceived sound quality can be established.

Measuring sounds inside cars often presents a difficult task for the acoustical engineer. There are two main reasons for this. First, there are no industry wide standardized measurement procedures. Second, very complex sound situations in the interior of cars, attributable to different transmission paths for airborne and structure-borne sound, are not easily identifiable in terms of most acoustical measurement technology. The objective criteria required for noise annoyance, sound quality or sound comfort cannot be obtained by simple A-weighted SPL measurement of sounds inside cars.¹

Investigations using binaural measurement and analysis techniques have demonstrated advantages for objectively determining sound quality.² The use of Artificial Head technology in conjunction with psychoacoustic evaluation algorithms, while taking into account the binaural signal processing capability of human hearing, has considerably advanced the analysis of sounds inside cars. The automobile industry has been in the forefront of application of these techniques. Aurally-equivalent sound measurement provides a workable means of classifying those sound components which significantly influence acoustic comfort.

The current trend in the automobile industry is to build increasingly lighter models with engines of higher performance. This results in higher vibration levels from the engine and, at the same time, higher probability of vibration excitation of car body components, particularly in the frequency range below approximately 1000 Hz. Not only are vibrating body components a source of sound annoyance, there is also the sound radiated directly from the engine because it is only slightly attenuated by the insulation or lack of insulation offered by lighter body components such as the bulkhead between the engine and passenger compartments. All of these sources of airborne sound produce, for the vehicle occupants, sensations and annoyance that vary substantially with operating conditions.

Low-frequency components up to an upper limit of approximately 400 Hz are experienced as acoustically unpleasant "humming" and "howling." Additional annoyance results from direct transmission of vibration to the occupants. These are experienced as disturbing vibrations on the floor, in the seating and in the steering and gear shift lever. The "sensitivity" threshold for the body as a whole to vibration extends to 200-300 Hz. Individual parts of the body, such as the finger tips, act as fine sensors in a frequency range of up to approximately 600 Hz.

These effects can only be traced to a particular cause if ad-

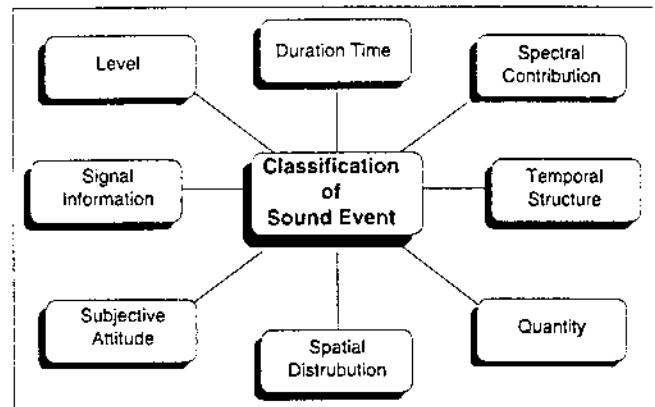

Figure 1. Parameters relevant to the classification of sound using human hearing.

ditional information about possible structural transmission paths can be obtained at the same time under the same conditions. This leads to the desirability of recording acoustic data with an artificial head, and vibration data simultaneously through multichannel measurement systems. The basis of a new approach to measurement and engineering for objective determination of subjectively experienced sound quality is created from two sources: first, the interconnection of airborne sound events with structure-borne signals at the engine; and second, the inclusion of vibration paths, such as, the transmission characteristics of the engine mounts, in the correlation process. The structure-borne sound measurement results can be visually represented not only as order analyses and spectrograms but also as running modes. With the new measurement procedure it is possible to display simultaneously vibrations from the sound source and airborne sound events recorded simultaneously with the artificial head.

In recent years, artificial head measurements have proved to be effective for identifying actual sound conditions. Together with the corresponding analysis and visual representation possibilities, this technology provides engineers with a tool for processing and modifying actual acoustic conditions aurally-equivalently. Technical evaluation becomes a reality. Measuring the SPL with a single microphone does not give sufficient information about the disturbing sound event. Even at low frequencies, measurement points in close proximity often show large differences in level. Annoyance experienced subjectively is often due to the difference in level or sound structure from one ear to the other, rather than the particular level value measured at any one point.³

Because auditory impressions are the key to assessing sound quality, the next section will review the psychoacoustic technology and knowledge which forms the foundation of much sound quality investigation and engineering. The remaining sections describe implementation of the multi-channel analysis system for combining binaural analysis with multiple signal recording and analysis and give an application example.

Aurally-Equivalent Measurement Technology

Aurally-equivalent sound measurement technology is concerned with objectively definable parameters that relate to human perception. Evaluation of a sound event by the "communications receiver" in human hearing is influenced by numerous parameters. These are diagrammatically summarized

Reprinted with permission from SAE, 931330© 1993 Society of Automotive Engineers, Inc.

in Figure 1. This shows that a sound event cannot be evaluated on the basis of a single dimension. Level is one of numerous parameters which play a part in the evaluation of a sound event by a person. These parameters are basically of two kinds: subjective (psychological) and objective (physical and psychoacoustic). Subjective parameters are best determined statistically because of the variability of human responses to a particular situation. It is difficult to derive precise parameters from them. This underlines the need for objectively based and aurally-equivalent sound measurement technology.

Regulations for fixing noise levels are based on A-weighted SPL measurements obtained using a single microphone only. Such a simple measurement procedure has limited utility for quantifying the annoyance in sound events or even sound quality in general. For many years A-weighted SPL measurement has been used to estimate the psychoacoustic parameter of loudness. A loudness measurement which takes better account of the spectral and temporal structure of a sound event than the A-weighted SPL has been shown to have advantages.¹ However, loudness has not been universally successful for quantifying sound quality. This is because complex sound events evaluated by loudness measurement equipment are not easily compared with the evaluations made by the human ear.

The difference can be explained by the evaluation of sound signals in the hearing process. While evaluations by means of conventional acoustic measuring techniques are made with simple A-weighting, human hearing has more complicated level-dependent evaluation mechanisms. A sound impression is not only determined by the sound pressure level, but also by psychoacoustic parameters, such as loudness, sharpness and roughness. A correctly tuned instrument sounds pleasant when compared with an out of tune one, although they have the same A-weighted sound pressure level and 1/3-octave spectrum. Due to the so-called pre-, post- and simultaneous masking effects of human hearing, different sound impressions may be created at the same A-weighted sound pressure level, depending on the temporal order of the signals and their spectral distribution. The measurement procedure for loudness takes into account the distribution of critical bands in human hearing. Thus, the masking effects and tonal components of a sound can be registered better. Loudness not only depends on the sound pressure level, but also on the spectral composition of the sound. The measurement of loudness (unit: sone) is a considerable step towards human hearing equivalent sound measurement. Sharpness (unit: acum) depends on the spectral composition. A sound is judged to be sharper and thus more annoying if the high-frequency spectral components are more prominent than low-frequency ones. Roughness of signals with strong temporal structure is caused by amplitude and frequency modulations, i.e., fast changes in level and frequency. Due to the filtering properties of the outer ear, each change in frequency simultaneously results in a more or less strong change in amplitude.

Human hearing is a highly sensitive system, but has only a limited longtime memory. Consequently when human hearing has experienced a sound event judged to be unpleasant and annoying, these parameters will continue to obtain, even when the noise is reduced by 2 or 3 dB or even more. When human hearing has been sensitized with respect to a given sound event pattern, it is not able to make an objective evaluation when the sound quality or noise component as a whole is modified.

In this connection, not only is the sound pressure level important, but also the duration of exposure, the spectral composition, the time structure and also the number and spatial distribution of the sound sources. If a sound event originates not from a single but several sound sources, which may also be spatially distributed, a correct evaluation of the sound event can only be obtained through binaural signal processing.

Binaural technology, the key component of aurally-equivalent measurements, comprises: (a) recording of sound by means of an artificial head measuring system; and (b) analysis incorporating an evaluation algorithm analogous to human hearing.

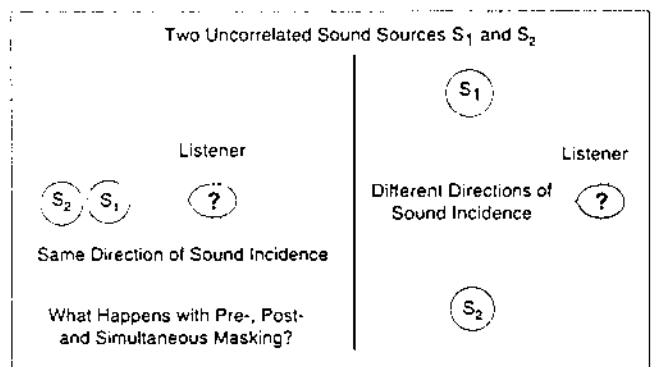

Figure 2. Illustration of the influence on hearing sensation caused only by the spatial distribution of two sound sources.

Aurally-equivalent sound measuring technology is not therefore an alternative to, but an important extension of, existing sound measurement techniques. In complex sound situations, which cannot be defined in terms of A-weighted sound pressure level alone, aurally-equivalent measurements can be used for gathering additional data, necessary for an objective evaluation of the sound event. The following points must therefore be noted:

- Simple physical measurement values such as A-weighted sound pressure level and third octave spectrum do not provide full information about sound events.
- The subjective sound impression is also determined by the psychoacoustic characteristics of human hearing.
- Human hearing comprises two input channels, which together with selectivity, create spatial hearing and therefore, in the case of several spatially distributed sound sources, yield results different from those provided by monaural measuring procedures.

The outer ear is a strongly directional filter.⁵ These filtering properties, i.e., frequency dependent responses, of the human outer ear arise through diffraction and reflections caused by the outer geometry which include pinna, head, shoulder and torso which are dependent on direction and by resonances which are independent of direction. In contrast, a standard measuring microphone has a linear, frequency independent response characteristic for all directions of sound incidence. These filter properties of the outer ear are very important for further signal processing at the receiver end of "human hearing."

A second difference between human hearing and conventional acoustic measuring methods is the fact that man has two auditory channels. The other ear is not simply a spare. It allows spatial discrimination essential for pattern recognition in conjunction with directional hearing, selectivity and suppression of noise. In a complex sound situation with various spatially distributed sound sources radiating different signals with the same acoustic power, the elimination of a single sound source leads to a very insignificant reduction of level as measured with a single microphone. In contrast, human binaural hearing is able to perceive considerable changes, depending on the temporal structures of the signals. This binaural signal processing is essential for everyday life, for example, speech communication in a noisy environment is only possible through binaural signal processing.⁶

Prior to introduction of binaural measurement technology, almost all acoustic measuring technology consisted only of single-channel sound event analysis in which measurements were carried out using a single microphone with a spherical directional pattern. Aural evaluation of sound events changes however, when there are several sound sources and when the ear is exposed to sound from several different directions. Figure 2 illustrates this complex situation. In the left section, the test person is confronted with two signal sources co-located. In the right section, these two signal sources are situated at different sound exposure angles with respect to the listener.

A significant difference immediately becomes apparent. If

each signal source emitted exactly correlated signals of exactly opposite phase from a position exactly geometrically symmetrical with respect to the center point, they would cancel each other and no sound pressure level would be measurable. Due to the spatial separation between the ears at the human head and the resulting interaural level and phase differences, human hearing perceives only slight attenuation of low-frequency components, while the high-frequency spectral components impact the human ear almost uncorrelated. For frequencies above 300 Hz, therefore, no further difference is measurable. Whether the signals are emitted in opposite or simultaneous phase, the sound pressure level remains unchanged. However, the psychoacoustic effects such as simultaneous, pre- and postmasking change when the masker and the signal to be masked are located at different angles of incidence to the ear. Figure 3 illustrates this phenomenon using a simple example. It is an example of simultaneous masking in which a 4 kHz pulse tone with a 1/3 octave band of noise at 4 kHz, are located 80° to the right and 50° to the left respectively. Measurement using a standard microphone, left panels, leads to a result completely different from that obtained when using an artificial head measuring system. Whereas in the first case the pulsating pure tone cannot be perceived, it can clearly be perceived in the second signal when the artificial head microphone signals are played back. The reason for these different effects is partly due to the filtering properties of the human outer ear and partly due to the binaural signal processing of hearing.

It became obvious that a human hearing equivalent analysis of sound quality or noise is only possible if all properties of human hearing are taken into consideration. This means that a simple measuring microphone is insufficient. A special artificial head measurement system,⁷ (Figure 4) is needed having transfer functions comparable to human hearing. The analyzer is not just a simple 1/3-octave or fast Fourier transform analyzer, but an analyzer with high resolution in the time and frequency domains and a high dynamic range comparable to human hearing.

A frequency weighting algorithm which is more complex and complicated than the standard A-weighting curve commonly used up to now is imperative. The algorithm needs to account for directional and body and head shadow effects. While the above mentioned psychoacoustic properties, such as loudness, roughness and sharpness can be determined by adequate algorithms, binaural signal processing of human hearing has not been examined completely. Binaural signal processing is necessary in order to recognize the direction of sound incidence or to select individual sound sources from a mixture of sounds. The formation of binaural loudness, sharpness and roughness will presumably vary if artificial head signals are analyzed rather than signals recorded with standard microphones.

The principal idea of head-related transmission is shown in Figure 5. Two microphone signals, recorded with the artificial head, are equalized to obtain signals compatible with conventional measuring microphone output. For subjective evaluation of sound events, these signals are played back using headphones equalized by correction filters. This creates the same signals in the ear canal of the listener as if the listener had been in the original sound situation measured by the artificial head.

The problems of human hearing equivalent sound evaluation described here have been known for a long time. The dBA measurement has been used since 1950 – first because it could be made relatively simply and second because confusion resulting from different measurement procedures could be avoided. Thirty years ago the ISO and the predecessor to ANSI did standardize the dBA measurement, while indicating that a human hearing equivalent measurement procedure needed standardization. The hitherto known psychoacoustic measurement procedures, in particular the loudness meter, were not satisfactory since they only took into account a part of human hearing equivalent sound analysis. Because binaural signal processing was neglected, there were often doubts as to whether simple loudness based on recordings with one micro-

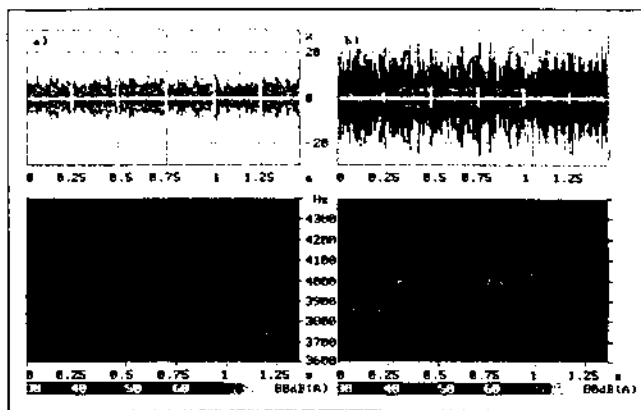

Figure 3. Changes in simultaneous masking during binaural signal processing under the assumption that the masking (1/3 octave band of noise at 4 kHz) and the masked signal (pulsed 4 kHz sinusoid) are emitted from spatially different directions: (a) recording with a standard microphone; (b) recording with an artificial head measurement system.

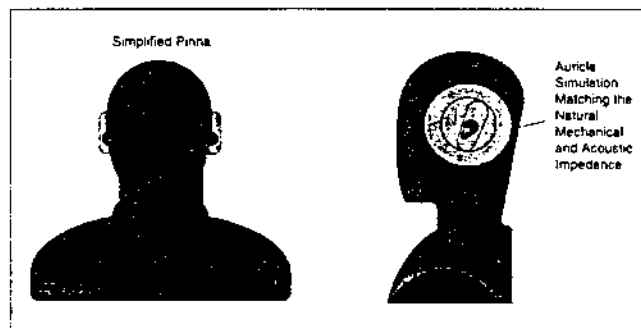

Figure 4. Artificial head measurement system with mathematically definable geometry, calibrateable transmission characteristics and built-in free field as well as independent of direction equalizers ensuring compatibility with conventional measurements.

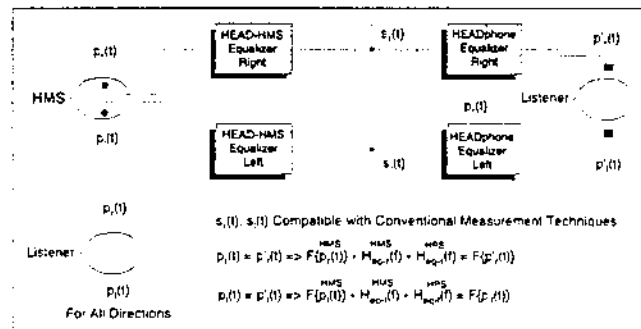

Figure 5. Principle of head-related transmission.

phone produced better results than measurements of the A-weighted sound pressure level. Now, the results obtained through aurally-adequate binaural measurement technology provide significant improvements in the ability to produce measurements appropriate to sound quality evaluation and engineering. The combining of these techniques with simultaneous capture and analysis of mechanical or other information about the system, adds more capability for refining the task of efficiently and economically improving product sound quality.

Multi-Channel Analysis

Having shown binaural measurement technology to be particularly useful, it can now be shown that a measurement technology combining audible observations with measurements of the sources of the sound will yield much additional information for efficient sound quality engineering and design of products. The procedure represented by diagrams in Figures 6 and 7 provides a basis for combining signals from an Artificial Head measurement microphone with signals from vibration sensors. This is particularly suitable for diagnosis of sounds inside cars.

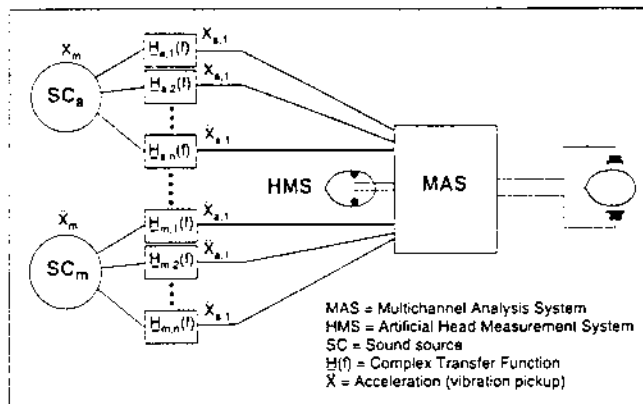

Figure 6. Block diagram of method for combining artificial head microphone signals with signals from acceleration measurements.

Auditory evaluation by test persons allows selection of individual signal components from the total sound which are judged to be annoying. The correlation of what is heard with signals from acceleration sensors makes it possible to discover the origins of these sound components and their transmission paths before they reach the interior of the car. Figure 6 shows the basic idea. The sound in the interior of a car arises from several sources SC_a to SC_m arriving from various transmission paths $H_{a,1}$ to $H_{m,n}$. Moreover, the sound impression is determined by the way the radiation of airborne sound from the individual noise sources within the car arrive at a person's ears.

Figure 7 shows the procedure used for analyzing transmission of a single engine noise. The engine noise reaches the interior of the car via the engine suspension in the form of structure-borne sound. This transmission can be recorded as the accelerometer signals on each side of the engine mount(s). The radiated airborne sound source is most likely unknown as study of a problem begins. The artificial head measurement

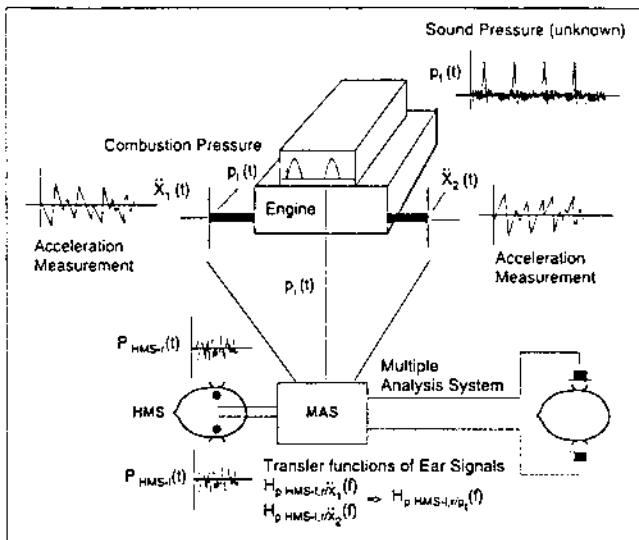

Figure 7. Analysis method for evaluating sources of airborne sound and engine noise with an artificial head measurement and engine motion sensors.

system can be used to record the resulting airborne sound inside the car. Inspection of signal characteristics: time of occurrence, spectrum, amplitude, etc., from each measurement location while listening to them and to the acoustic signal recorded through the artificial head can be carried out in a manner similar to one used for identification of only the airborne or acoustic features of the sound in the vehicle. In this way, conclusions as to the unknown airborne sound transmission path may be related to the mechanical properties. Such a procedure provides a rapid and appropriate method of finding the various sources of sounds to improve sound quality inside cars.

Polytec Scanning Laser Vibrometer

Measure vibration fast, accurately and without contact

Use the Polytec PSV-100 turn-key, scanning laser system for automated, full-field vibration measurement and analysis. Test a wide variety of structures including car body panels, running motors, jet engine components, appliances, power tools and electronics packages.

To learn more about the award winning Polytec PSV-100, call now for technical specifications or to arrange a demo.

- Easy setup saves time & money
- Make heretofore impossible tests—remotely!
- See the test—live video image overlays the test area
- No added mass or local stiffness, no surface preparation
- >140dB amplitude range; test many different parts
- Easy data transfer to modal software programs
- Built-in high performance 2 channel FFT processor

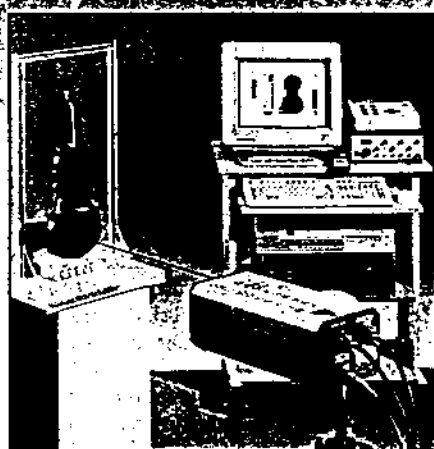

East Coast Office:
23 Midstate Dr., Suite 104
Auburn, MA 01501
☎ 508 832 3456 / FAX 508 832 0506

West Coast Office:
3152 Redhill Ave., Suite 110
Costa Mesa, CA 92626
☎ 714 850 1835 / FAX 714 850 1831

Germany: Polytec GmbH
☎ + 7243 6040 / FAX + 7243 69944

France: Polytec PIRMP
☎ + 1 4700 2800 / FAX + 1 4700 2904

Japan: PI Polytec KK
☎ + 0081 425 26 7300 / FAX + 0081 425 26 7301

Great Britain: Lambda Photometrics Ltd.
☎ + 582 764334 / FAX + 582 712064

Circle 127 on Inquiry Card

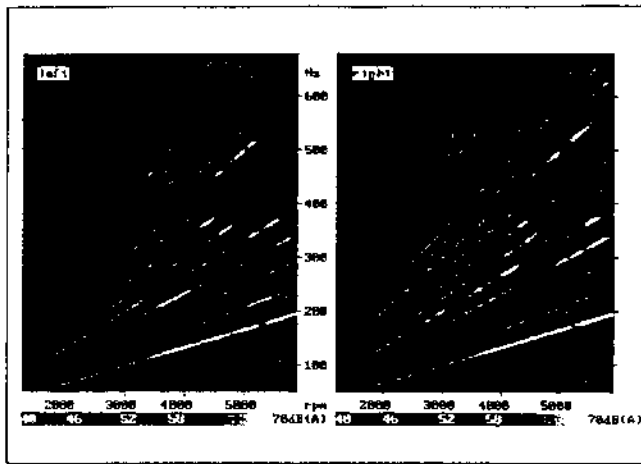

Figure 8. Left and right ear signals of the artificial head for engine acceleration over the range 1000 - 6000 rpm.

A new eight-channel DSP board was developed at HEAD acoustics to facilitate the efficient processing of the large amount of data available from this multiple channel identification of sound sources. This hardware allows real-time analysis of several channels. An order analysis can be extracted from the individual channels, for example. A large number of orders may then be viewed with respect to rpm in real-time. Thus the orders in particular rpm ranges that must be modified in order to reduce the annoyance factor can be identified to obtain a more acceptable noise design.

The combination of artificial head measurement technology, multichannel vibration analysis and digital signal processing suggests that future innovation in vehicle and product design for sound quality may be characterized by speedier and even more objectively oriented development.

Application

An analysis using this multichannel approach to solving a sound quality problem is shown next. The test vehicle was a front-wheel drive car of the lower middle performance and price range. It had a four cylinder transversely suspended 1.6 l engine mounted at three points. The car exhibited good road behavior and a noise level typical for this class of vehicle. Below approximately 3000 rpm the interior noise level was strikingly low. Above 3000 rpm up to the maximum rpm, however, very disturbing humming and howling occurred. Binaural sound measurements were made in the front right side passenger seat position using the artificial head. This information provided acoustic information about the complaints. Base or reference condition measurement was made during acceleration/deceleration operation of the vehicle in third gear on a straight section of good surface road.

The artificial head signals were evaluated in the frequency range from 50 Hz to 2 kHz. In what follows, only the acceleration phase is presented. The spectrograms in Figure 8 show excessive increase for sound levels at both left and right ears in the frequency range 180 Hz to 650 Hz, and at engine speeds above 2800 rpm up to the maximum rpm. The frequency range includes, between the 2nd order at 5400 rpm (180 Hz) and the order 6.5 at 6000 rpm (650 Hz), the first three critical, i.e., high level orders, of the 4-cylinder in-line engine together with the corresponding intervening orders. The 2nd order itself is clearly identifiable over the total rpm range. Levels of the various orders appear to be somewhat more uniform over the rpm range at the right ear than at the left ear. The spectrograms provide a good general overview of all orders occurring over the rpm range. How can there be any observable difference in sound levels at these relatively low frequencies? If only wavelengths and head dimensions are considered, in most situations both ears would have essentially the same levels. Clearly the spectrograms show differences. It is these differences that give rise to annoyance.

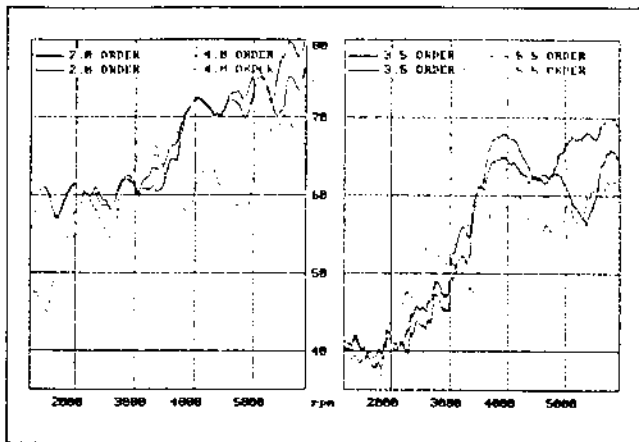

Figure 9. Order analysis of the data shown in Figure 8: (a) 2nd order, solid lines and 4th order, dotted lines; (b) 3.5 order, solid lines and 5.5 order, dotted lines. Red is right ear signal; green is left ear signal.

Views of individual order levels at the left and right ears vs rpm make it easier to show what is occurring, as shown in Figure 9. The 2nd order level, solid lines in Figure 9a, exhibited a distinct level increase of 5 dB between 3500 and 4000 rpm. Second order level differences between the left and right ears first become apparent above approximately 5200 rpm. To underline the left-right ear difference look at the doubled frequency, the 4th order dotted lines in Figure 9a. In this case, left-right ear differences are already apparent at rpm values above 3000 with level differences of up to 10 dB. Above 180 Hz, not only the total level increases, but also the left-right ear sound level difference increases and contributes to the total subjectively unpleasant impression. The graphs for orders 3.5 and 5.5 in Figure 9b likewise reveal strong level differences between the left and right ears at engine speed values above 3000 rpm.

Another important result pertaining to sound quality can be seen in these data. Noise impressions from engines are strongly influenced by roughness and fluctuation strength. These arise with engines because the various orders are situated very close together, especially in the case of multiples of half orders. Human hearing cannot then distinguish between the individual orders, i.e., frequencies. Only modulation of the individual orders will be heard. The psychoacoustic characteristics of roughness and fluctuation strength have been investigated under monaural laboratory conditions. The pronounced character of roughness and fluctuation strength has not yet been investigated for binaural signals. With binaural signals, as can be seen in the figures, the individual orders combine in different ways for the left and right ears depending on the operating engine speed. During auditory evaluation, however, the unpleasant and annoying impression in these rpm ranges only becomes apparent on binaural investigation. The impression is not revealed by monaural investigation. The interaural level differences of approximately 15 dB shown in Figure 9 are situated in the frequency range from 100 to 350 Hz. In natural sound exposure situations such level differences could not occur at such low frequencies. This is because in this frequency range, the shadowing effect of the head can be ignored. The human ear is not accustomed to such level differences at low frequencies. Such level differences occur in the interior of vehicles because transmission paths are very short and sound originates at very different locations with different operating conditions and orders. They produce an unpleasant sensation of very different pressure on the ears.

Another striking effect is evident when analyzing the two ear signals. In this test the right ear theoretically should exhibit higher signal components because of reflections from the adjacent window. The artificial head measurement system was located on the right-hand seat. Not only do significant level differences occur between the left and right ears but a higher level can occur at the left ear.

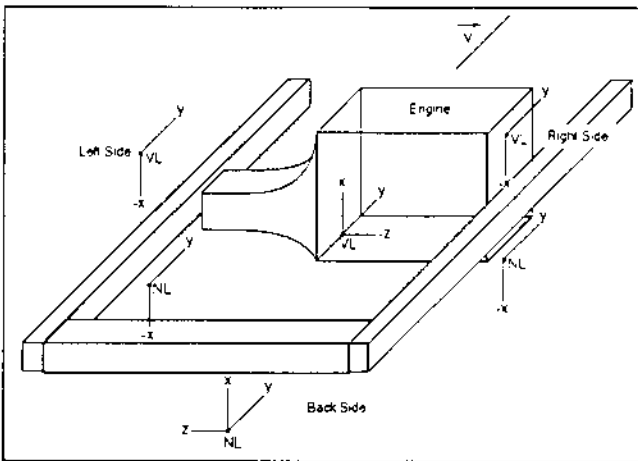

Figure 10. Schematic of engine mount and frame. Positions and directions of three measurement points are left, right and rear with triaxial accelerometers on each side of each engine mount.

As noted earlier in this article, airborne noise frequently may be due to structure-borne sound or vibration transmitted through engine mounts and other attachment components. Purely airborne sound excitation paths can only be successfully tackled once structure-borne sound transmission has been investigated, identified and isolated. In this example which is typical, structure-borne sound transmission from the engine is evaluated for the mounts in all spatial directions. Even with a very straightforward measurement procedure, the techniques produce a large quantity of data. With three engine mounts – left, right and behind, each with a triaxial acceleration sensor located on either side of the mount – a total of 18 accelerometer signals is produced (Figure 10). It thus becomes important to find a method of reducing the quantity of data needing analysis in a speedy and easily carried out manner. Airborne sound

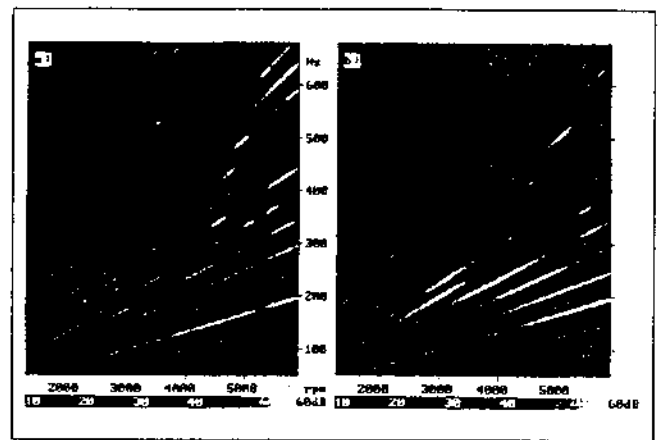

Figure 11. Order analysis spectrograms for the rear mount vertical direction acceleration: (a) engine side; (b) chassis side. The difference is a measure of the transmission of acceleration across the mount.

signals in the vehicle interior can be simultaneously recorded using the artificial head measurement system. Having both airborne sound information and vibration information allows more rapid location of noise source and transmission paths by auditory correlation with the signals originating from the individual acceleration sensors, the parameters affecting sound quality having been previously identified by listening. Figure

11 shows a spectrogram example of the various orders on the two sides of one of the engine mounts and in one direction. Comparative auditory evaluation while displaying the various acceleration signals produced a close correlation with motion in the vertical direction from the center rear engine mount. Through structure-borne sound analysis a distinct resonator behavior at approximately 200 Hz was identified as a significant source of the annoyance. This powerful resonance suggested presence of a bodywork resonance.

The New Concept in Vibration Testing

6 DEGREES OF CONTROL

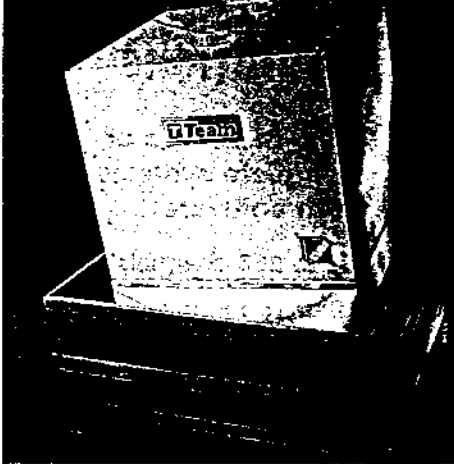

Introducing The Cube

TEAM Corporation is taking 6 Degree of Freedom testing a giant step forward. The Cube is an advanced technology hydraulic test system that offers 6 Degrees of Control. Now you can accurately replicate virtually any condition, including very high frequencies, with precise, digital control.



TEAM Pitch Tables.

Squeak and Rattle analysis on automobile seats is accomplished with great efficiency with TEAM's Hydrashaker-based Pitch Tables. Two simultaneous motions (bounce and pitch) are produced. A built-in air isolated reaction mass allows this system to be installed on most facility floors.



Improved product quality through advanced vibration test solutions

1159 Water Tank Rd. Burlington, WA 98233
Phone: (360) 757-8601 Fax: (360) 757-4401



Low-Pass Filter Boards for A/D Converters



Full Software Programmability

- Pre-filter gain for $\pm 2.5mV$ to $\pm 10V$ input
- 1Hz to 100 kHz programmable frequency range (up to 250 kHz optional)

Filter Type and Channel Flexibility

- Compatible with any A/D converter
- 2 to 8 filter and/or gain channels per board, unlimited number of channels per system
- Choice of 5-pole Cauer elliptic, linear phase, Butterworth, and Bessel filters

For Your FREE Short-Form Catalog
Call (714) 850-9984



Alligator Technologies

2900 Bristol Street, Suite E-101
Costa Mesa, CA 92626-7906
714-850-9984, fax 714-850-9987

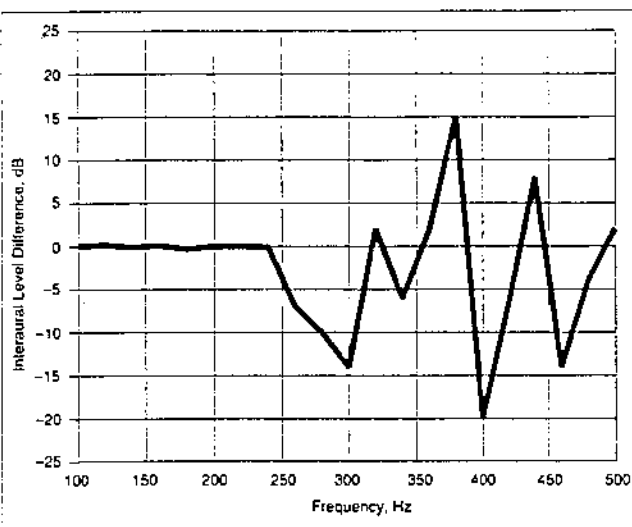

Figure 12. Interaural level difference of artificial head ear signals when the chassis is excited with a shaker attached directly to the middle engine mount position.

To support the theory that bodywork was being vibrationally driven from that engine attachment point, a shaker was used to excite the bodywork at the attachment point. The transfer function of the airborne sound in the interior relative to the force at the point of excitation was recorded with an artificial head. The result of this experiment, shown in Figure 12, can be interpreted as follows: the shift in sound level function from one side of the head to the other, in the frequency range above 200 Hz, is explained by the shift in level curve in the 2nd order in the rpm range above 5000 rpm (Figure 9a) and the level differences in the order 3.5 in the rpm range 3500 to 4000 rpm (Figure 9b). The level difference for the order 3.5 above 5000 rpm is also clearly shown when the bodywork is excited at ap-

proximately 300 Hz. Significant vibration sources and paths can thus be identified step by step and related to the individual orders present in the noise analysis, as in Figure 9. Further, this example shows the respective order analyses of the acceleration signals from each mount, as well as the bodywork transfer function which result when the bodywork is excited at the mount attachment points. Relevant information is thus quickly made available to the design engineer as to how the bodywork attachments can be modified for example by changing their rigidity.

Summary

The combination of reliable and realistic artificial head recording of sounds inside cars with a multichannel structure-borne sound analysis system provides acoustical engineers with new possibilities of achieving the objective of improved noise design at reduced time and cost. The additional possibility of subsequent digital signal processing also brings the objective of higher acoustic comfort a step nearer.⁶

References

1. K. Genuit, "Procedure for Objectivation of Subjectively Perceived Sound Quality," *IMEchE*, June 1992, London.
2. K. Genuit, M. Burkhard, "Artificial Head Measurement Systems for Subjective Evaluation of Sound Quality," *Sound and Vibration*, March 1992, p. 18.
3. K. Genuit, "Significance of Binaural Technology for Aurally-Adequate Sound Measurement Technique," ICA'92, September 1992, Beijing, China.
4. E. Zwicker, H. Fastl, *Psychoacoustics*, Springer Verlag, New York, 1982.
5. K. Genuit, "Analytical Description of Average Outer-Ear-Transfer-Functions in Dependency of Sound-Incidence," 11th ICA Paris 1983 Tagungsband Vol. 3, pp. 9-12.
6. H. vom Hövel, "Zur Bedeutung der Übertragungseigenschaften des Außenohres sowie des Binauralen Hörsystems bei gestörter Sprachübertragung, Diss," RWTH Aachen 1984.
7. K. Genuit, "A Special Calibratable Artificial-Head-Measurement-System for Subjective and Objective Classification of Noise," *INTERNOISE* July 1986, Cambridge, MA, pp. 1313-1318.

Turn Your Multimedia PC into a Powerful Real-Time Spectrum Analyzer

Features

- Dual channel FFT Analyzer
- Narrowband and 1/3 Octave
- Real-Time, Record, Playback, or Post Process
- Time Series, Spectrum, Phase, 256 Color Spectrogram and 3-D Surface plots
- FFT sizes through 16,384 pts
- Digital Filtering
- Signal Generation
- Decimation and Triggering
- Overlap Processing

Applications

- Acoustic Research
- Distortion Measurements
- Noise Analysis
- Frequency Response Testing
- Vibration Measurements
- Transfer Function Measurements

System Requirements

- 386/486/Pentium and Windows 3.1
- Windows compatible sound card
- 4 MB RAM minimum
- Mouse and Math coprocessor
- 256 Color VGA (for spectrogram)

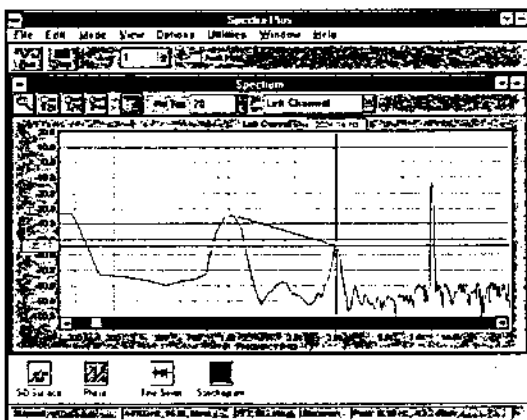

\$395 Software only

\$629 Software plus pro quality* sound card

*DC-15kHz flat to 0.2 dB, THD < 0.005%, S/N - 90 dB
2 channel, 16 bit, 44.1 kHz sampling.

PCMCIA sound cards also available

Call Now for Free Demo Disk! 1-800-401-3472

PHS

Pioneer Hill Software
24460 Mason Rd. NW
Poulsbo, WA 98370

Affordable Signal
Processing Software

Spectra Plus
Professional Edition

Tech Info: 360-697-7733

Fax: 360-697-7730

BBS: 360-697-7717

We Build Data Acquisition Solutions

Plug-in boards or complete systems with software:

- Up to 256 channels
- 12 or 16 bit resolution
- Amplifiers and Filters
- Signal Conditioning
- Windows/DOS software
- Rugged computers for harsh environments
- Rackmount/Portable PC's

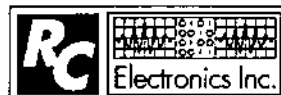

6464 Hollister Ave, Santa Barbara, CA 93117
805/685-7770, Fax 805/685-5853

The Innovative Leader in Test and Measurement Systems

Circle 130 on Inquiry Card

Circle 131 on Inquiry Card