

Modulation Analysis

Modulation analysis delivers the envelope spectra of partial bands of an analyzed signal. This allows the user to recognize amplitude modulations including their frequency, strength and change over time. While the psychoacoustic parameters roughness and fluctuation strength allow only certain modulation frequencies to be examined and judged (e.g. modulation frequencies around 4 Hz for fluctuation strength), a modulation analysis covers a wider frequency range, which also includes the roughness and fluctuation strength areas, and does not add psychoacoustic weightings.

Amplitude modulation

A continuous sound, whose amplitude varies sinusoidally around a mean value \hat{p}_{carrier} , is called a sinusoidally amplitude-modulated signal. The sound pressure $p_a(t)$ of such a sine tone is calculated with the following formula:

$$p_a(t) = \hat{p}_{\text{carrier}} \cdot (1 + m \cdot \sin(2\pi f_{\text{mod}} \cdot t)) \cdot \sin(2\pi f_{\text{carrier}} \cdot t)$$

f_{mod} :	modulation frequency
f_{carrier} :	carrier frequency
m :	modulation depth.

For a non-sinusoidal amplitude modulation, the first sine function in the formula must be replaced. Replacing the second sine changes the shape of the carrier signal.

The modulation depth m describes the strength of the modulation and is calculated as the ratio of alternating component to constant component of the signal.

Figure 1 shows a schematic representation of a sinusoidally amplitude-modulated signal.

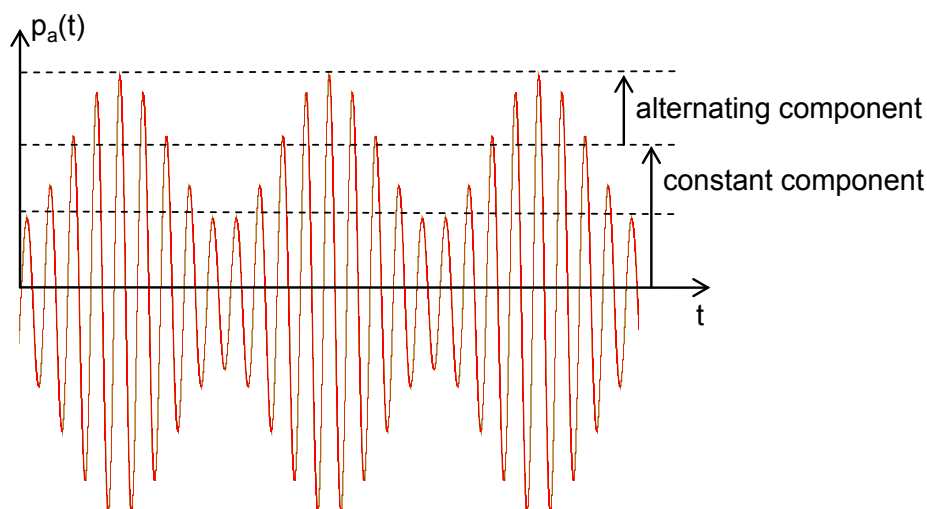

Figure 1: Schematic representation of an amplitude-modulated sine tone

Modulation analysis in ArtemiS

ArtemiS provides several different analysis functions to examine the modulation of signals. The following table lists and explains these functions.

Analysis	Description
Degree of Modulation vs. time / rpm	Analysis of the degree of modulation of a selectable frequency range over time or rpm 
Modulation Frequency vs. time / rpm	Analysis of the modulation frequency of a selectable frequency range over time or rpm 
Modulation Spectrum	Analysis of the average modulation factor of a selectable frequency range over the modulation frequency 
Modulation Spectrum vs. band	Analysis of the modulation factor over the modulation and carrier frequency 
Modulation Spectrum vs. time / rpm	Analysis of the modulation factor of a selectable frequency range over time or rpm and the modulation frequency 

Table 1: Description of the different modulation analyses in ArtemiS

In the Properties dialog, the setting of the respective analysis can be selected. The configuration dialogs for all of the analysis functions listed above are very similar. The left image of figure 2 shows the Properties dialog of the Modulation Spectrum vs. time analysis. In the upper part, the user can select the frequency range to be examined. This range can be determined by one of

the standardized octave, 1/3-octave, or frequency group filters. Alternatively, the user can use a custom frequency or order filter.

In the lower part of the configuration dialog, the settings for the maximum envelope frequency and for the FFT analysis of the envelope can be selected. In the Modulation Spectrum vs. band analysis, the modulation is examined in the entire audible frequency range, therefore the Properties dialog of this analysis does not allow selecting the frequency range to be analyzed (see figure 2).

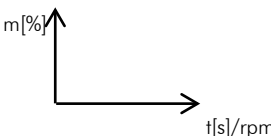
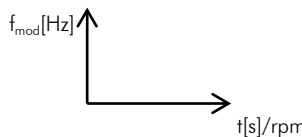
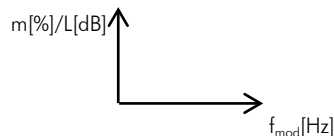
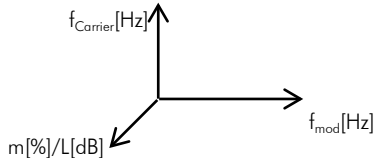
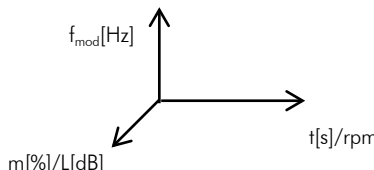
By selecting the Degrees of Modulation option, the result can be displayed as modulation factor with the unit [%]. If this option is deactivated, the signal level of the envelope is displayed directly. For the Degree of Modulation vs. time analysis, this option is not available in the Properties dialog, as this analysis always determines the modulation factor in the unit [%]. For the Modulation Frequency vs. time analysis, this option is not applicable as well, because this analysis does not examine the modulation depth, but only the modulation frequency.

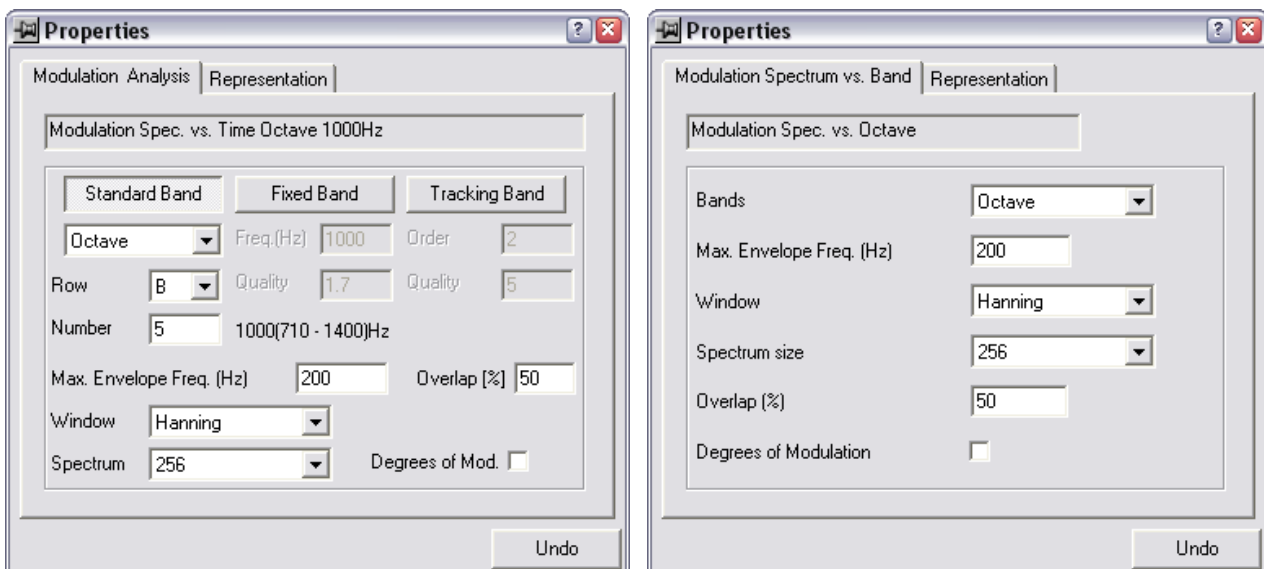

Figure 2: Properties dialog of the analysis functions Modulation Spectrum vs. time (left) and Modulation Spectrum vs. band (right)

Application examples

Figure 3 shows the different modulation analysis results of a sound signal generated by a combustion engine at idle speed. In addition, an FFT analysis is shown. The result of the FFT-analysis (figure 3a) shows that the frequency band between 140 and 200 Hz is significantly modulated. Therefore, for those modulation analysis functions that require a certain frequency band to be specified by the user, the octave band around 180 Hz (125 to 250 Hz) was selected. For the Modulation Spectrum vs. band analysis, a subdivision into 1/3-octave bands was chosen.

Figure 3b shows the result of the degree of modulation analysis. The octave band around 180 Hz is modulated with a degree of modulation of about 70 %. The degree of modulation is relatively constant across the entire duration of the signal. Figure 3c shows that the signal is modulated mainly with a modulation frequency (or rate) of approximately 16 Hz. This can also be seen in figure 3d, where the modulation frequencies and the corresponding modulation factor are displayed for the octave band around 180 Hz. This figure also shows that the signal is mod-

ulated with other frequencies as well. However, the degree of modulation for these modulation frequencies is significantly lower than for the 16 Hz modulation frequency. Figure 3e shows a spectrogram to illustrate which carrier frequency is modulated with which modulation frequencies. The color indicates the strength of the modulation. Again, this diagram shows that the most significant modulation frequency is approximately 16 Hz. The history of the modulation frequency and the degree of modulation over time is shown in figure 3f. Since the selected sound example is almost constantly modulated over the entire signal duration, this diagram shows only a small temporal variation.

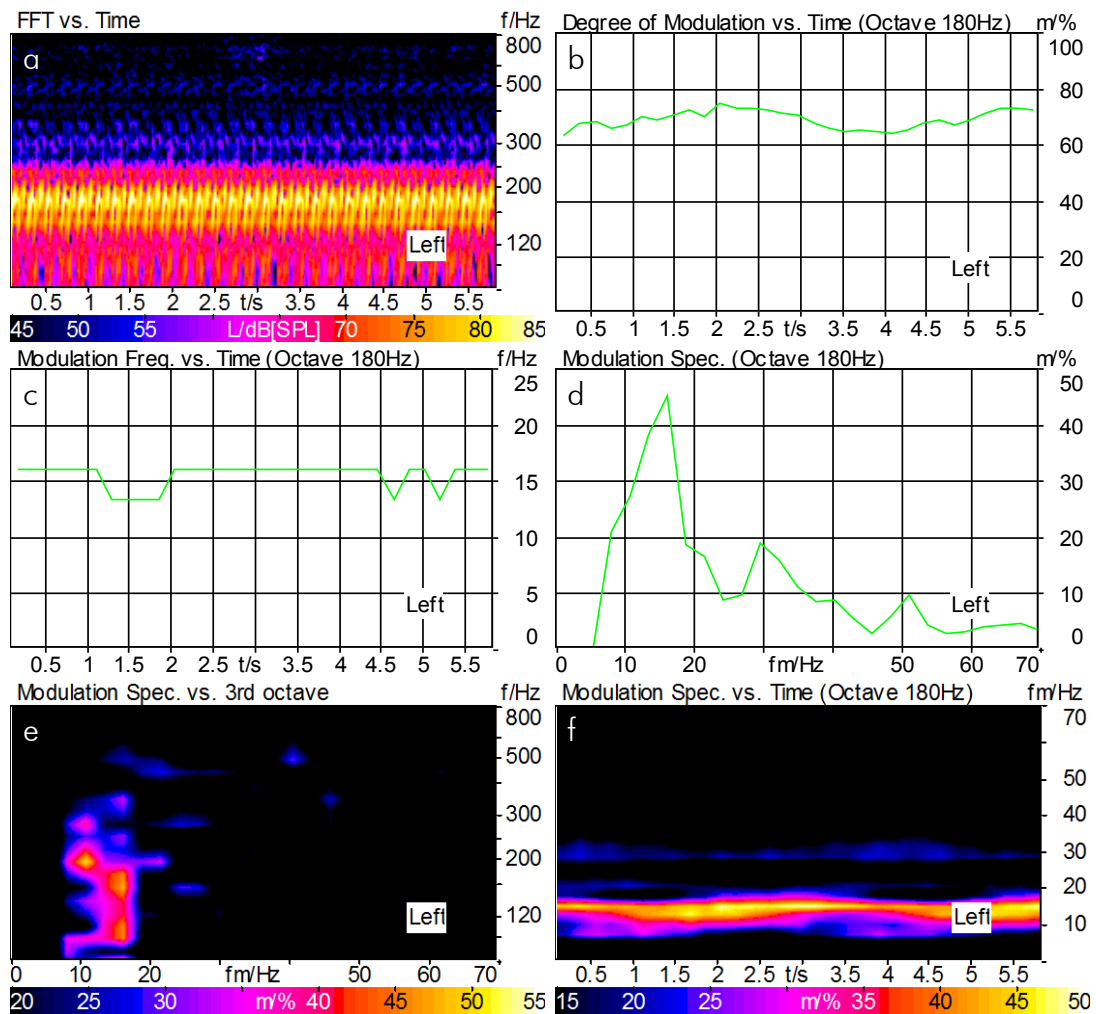

Figure 3: a) FFT vs. time analysis, b) degree of modulation vs. time, c) modulation frequency vs. time, d) modulation spectrum of the octave band around 180 Hz, e) modulation spectrum over 1/3-octave bands, f) modulation spectrum of the octave band around 180 Hz vs. time

Figure 4 shows the modulation analysis results of a sound recorded in a vehicle cabin at about 3000 rpm. The *FFT vs. time* analysis (figure 4a) shows that individual engine orders clearly stand out in the signal. The levels of the individual orders vary in the period of time shown. This causes the modulation frequency as well as the modulation factor to vary over time, too. For the analysis, the octave band around 250 Hz was selected. The temporal variations of the modulation can be seen very well in the diagrams 4b, 4c, and 4f. Because of the modulation frequencies

being between 15 and 35 Hz, neither a roughness analysis nor a fluctuation strength analysis would show the modulations present in this signal.¹

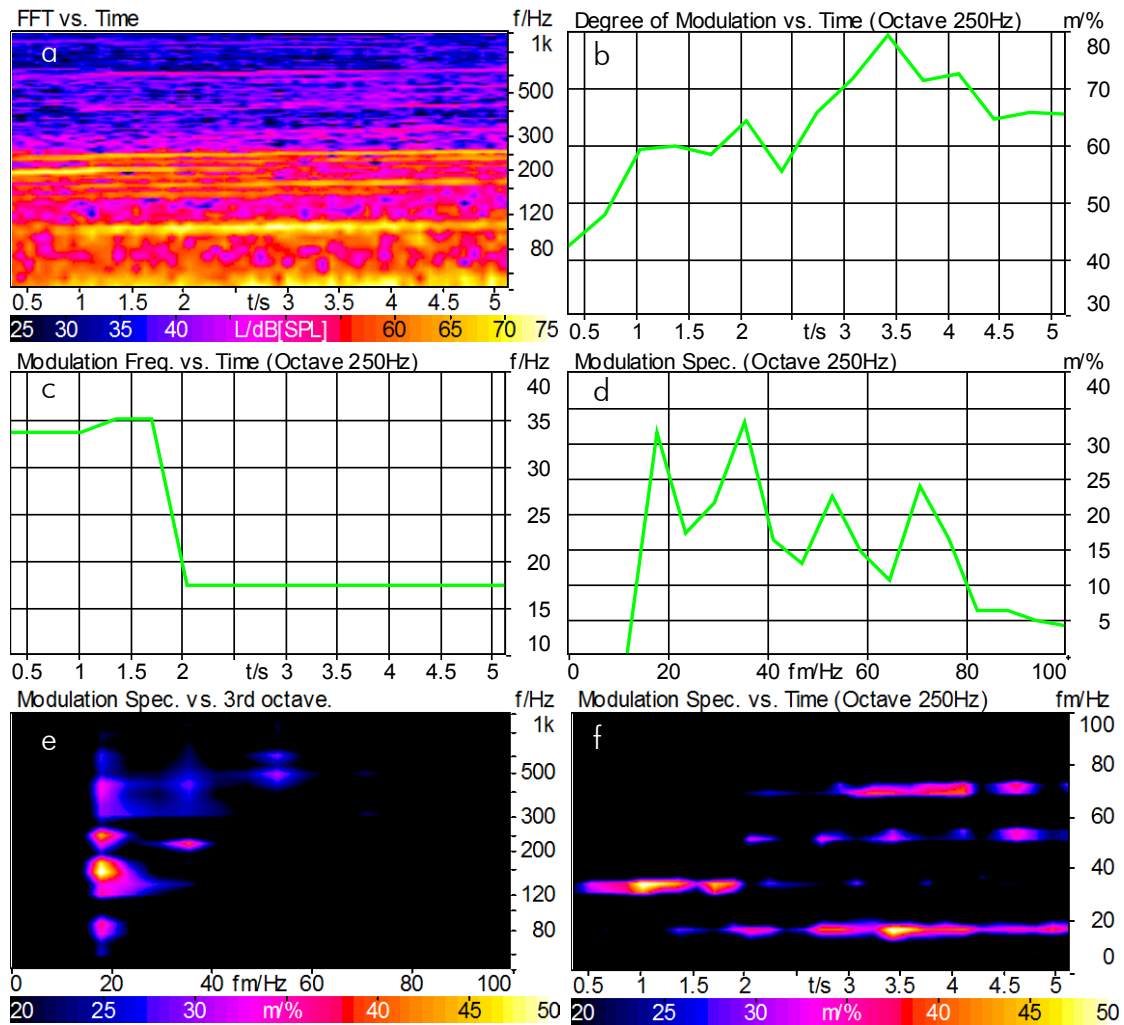

Figure 4: a) FFT vs. time analysis, b) degree of modulation vs. time, c) modulation frequency vs. time, d) modulation spectrum of the octave band around 250 Hz, e) modulation spectrum over 1/3-octave bands, f) modulation spectrum of the octave band around 250 Hz vs. time

Summary

If it is found that a signal is modulated, for example by viewing an FFT vs. time analysis or by listening to the signal, the first step that makes sense in most cases is a Modulation Spectrum vs. band analysis. The result of this analysis provides an overview of the modulation frequencies in the entire frequency range. Furthermore, the degree of modulation is shown as well. If the user already knows which signal frequency range might contain modulations, the Modulation Spectrum analysis is useful. This analysis determines the modulation factor and modulation frequency of a certain specified frequency range of the input signal. This analysis can be used, for exam-

¹ The Hearing Model Roughness analysis contained in the ArtemiS Tool Pack O6, which determines the roughness based on a human hearing model, allows roughness with modulation frequencies around 30 Hz to be detected.

ple, for quality tests if a product has a known fault that expresses itself in modulations in a certain frequency range.

For analysis of signals that change rapidly over time, the time- or rpm-dependent analysis functions (Degree of Modulation vs. time/rpm, Modulation frequency vs. time/rpm, Modulation Spectrum vs time/rpm) are recommended. These methods can show variations of the modulation. One possible application is modulation analysis of a sound recording of an engine run-up. For the analysis of signals containing rpm information, it is useful to employ order filters rather than frequency-dependent filters. The filter type can be selected in the Properties dialog of the respective analysis.

The various modulation analysis functions provided by ArtemiS guarantee that the user can always select a suitable analysis method according to specific needs.

Note

In order to use the features presented in this application note you will need the ArtemiS Basic version (Code 4600) and the ArtemiS Advanced Analysis Module, ATP 07 (Code 4607).

Do you have any questions or remarks? Please write to: imke.hauswirth@head-acoustics.de. We look forward to receiving your response!

Appendix 1: Frequency modulation

If the frequency of a signal is modulated rather than the amplitude, this is called a frequency-modulated signal. The left image in figure 5 shows the FFT vs. time analysis of a frequency-modulated sine tone. Such a signal can be examined with the modulation analysis functions provided by ArtemiS as well. However, this requires a very careful interpretation of the analysis results.

For the modulation analysis, the signal is divided into different frequency bands as already described above. Depending on the examined frequency range, the analysis yields different results. For a frequency-modulated signal, this is shown schematically in figure 5. When a frequency-modulated signal is divided into individual frequency bands, amplitude-modulated signals are created, which can then be examined with the modulation analysis functions in ArtemiS.

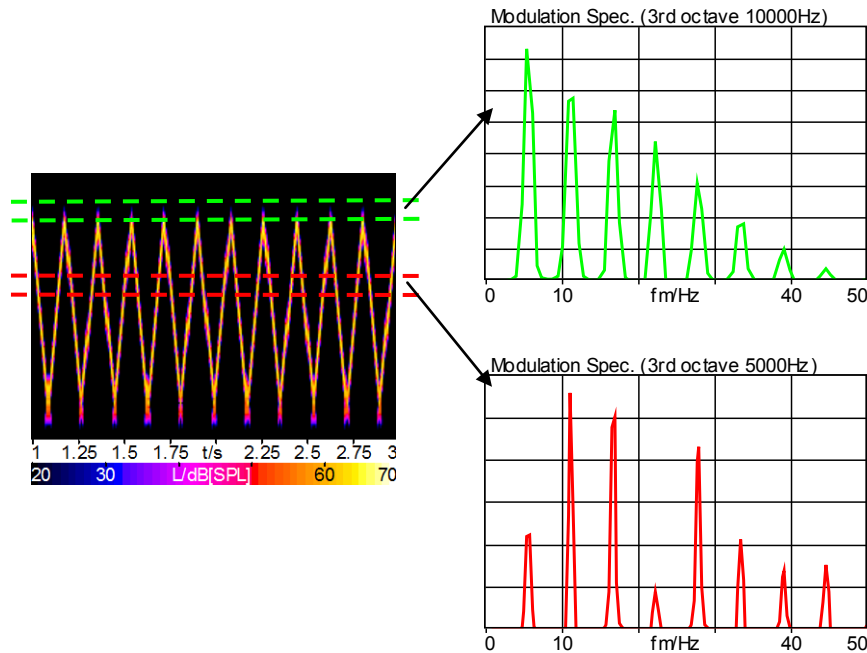

Figure 5: Modulation analysis of a frequency-modulated sine tone

The modulation frequency of the amplitude modulation equals the original frequency modulation or a multiple thereof. The modulation spectrum of the frequency range marked in green in figure 5 contains, as its main component, the modulation frequency of the frequency modulation of about 5.5 Hz. The analysis of the range marked in red shows a modulation frequency of about 11 Hz as its main component, i.e. twice the actual modulation frequency of the frequency modulation. In order to determine which frequency band is suitable for the modulation analysis of a frequency-modulated signal, it is recommended to always perform an FFT vs. time analysis in addition to the modulation analysis, to provide the required information for the interpretation of the modulation analysis results.

Appendix 2: Calculation steps of the modulation analysis

As mentioned before, modulation analysis is the spectral analysis of the envelope of a signal. Figure 6 shows a schematic diagram of the procedure used in this analysis. Below the individual calculation steps are briefly explained.

In the first step, the input signal is filtered with an IIR band-pass in order to extract the frequency range specified in the Properties dialog. An octave band, a 1/3-octave band, or a frequency group can be selected. A Butterworth filter of 4th order is used for filtering. If high frequency components were removed by this filtering, a first downsampling can be performed, because the sampling rate can be reduced depending on the selected frequency range.

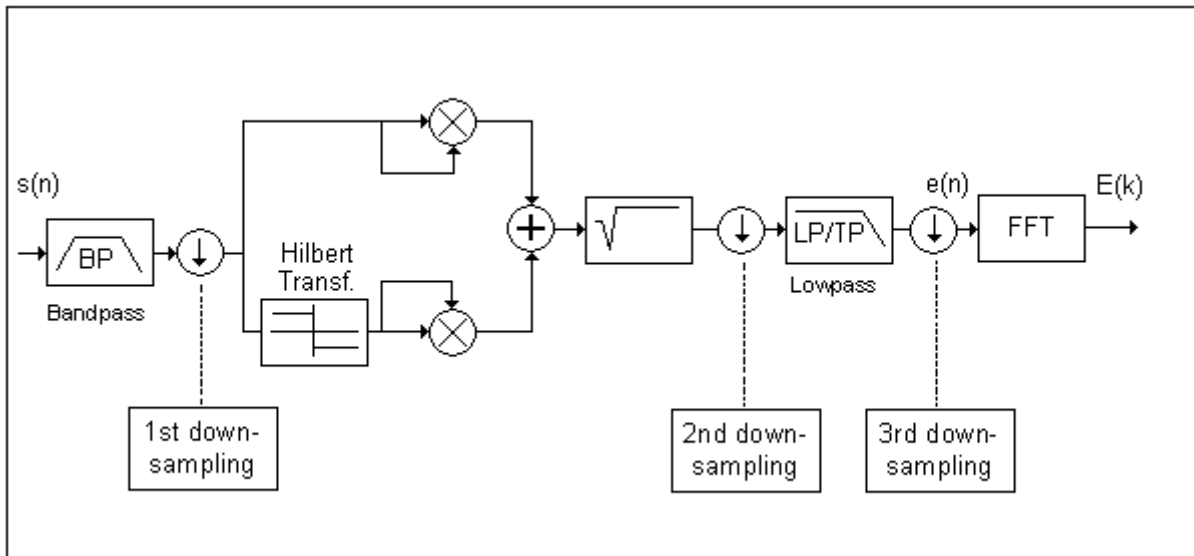

Figure 6: Schematic diagram of modulation analysis steps in ArtemiS

This downsampling reduces the calculation time, but primarily it improves the quality of the subsequent Hilbert transformation. This transformation determines the imaginary part of the complex envelope from the input signal. The real part of the envelope is given by the input signal itself. In the next step, the actual envelope of the signal is calculated, which equals the absolute value of the complex envelope. This means that the squares of the real part (the band pass signal) and the imaginary part (the output signal of the Hilbert transformation) are added, and the square root is extracted from the result.

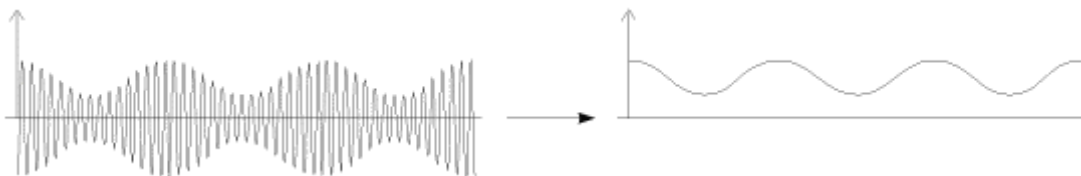

Figure 7: Determining the envelope

The envelope is then downsampled again according to the bandwidth of the selected frequency range, and filtered by a low-pass. This is done using a filter of 2nd order, whose cut-off frequency can be selected in the Properties dialog (Max. Envelope Freq.). The selected frequency should be above the highest modulation frequency up to which the analysis is to be calculated. According to the cut-off frequency of this low-pass filter, the signal is then downsampled once more.

In the last step of the modulation analysis an FFT analysis of the envelope is performed. In the Properties dialog of the analysis, the user can specify the window function (Window), the window width (Spectrum/Spectrum Size) and the overlapping (Overlap) for the FFT analysis. These parameters can be used to influence, for example, the time and frequency resolution of the analysis.